

Bradley
AUSTRALIA

customised excellence

www.bradleyaustralia.com

MODEL SR0941-16

SORRENTO SHOWER SHELF



PRODUCT FEATURES:

- Polished stainless steel with two post assembly
- Surface mounted

Overall Dimensions
400mm W centres x 110mm projection

PRODUCT DATA:

CONSTRUCTION:

Fabricated of polished stainless steel with 18mm diameter posts.

INSTALLATION:

Secure to wall with mounting screws (included) at holes provided.

GUIDE SPECIFICATION:

Shower shelf shall be fabricated of polished stainless steel with concealed mounting flanges in sizes and configurations as indicated.

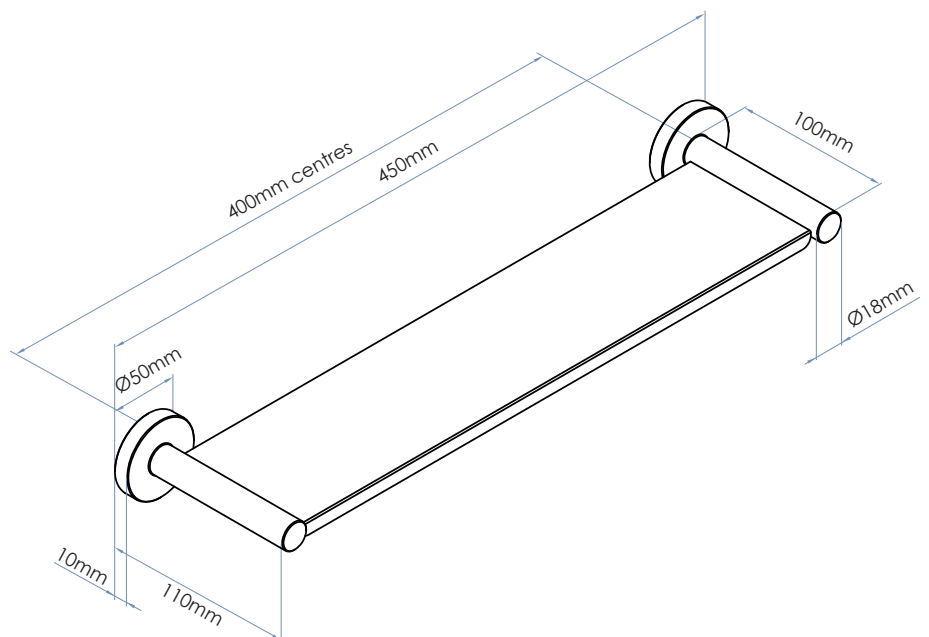

1300 364 561

The manufacturer reserves the right to make changes in design and material without formal notice and without incurring obligation.

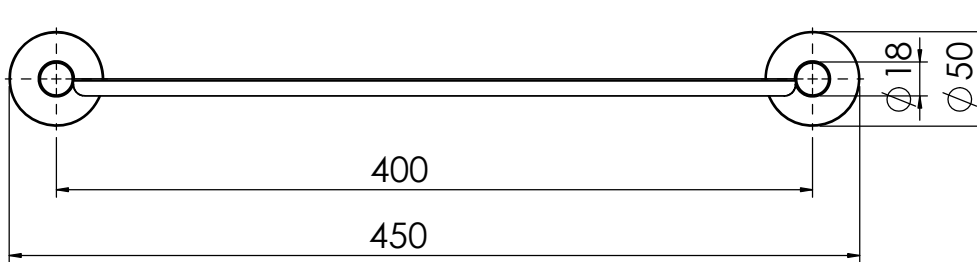
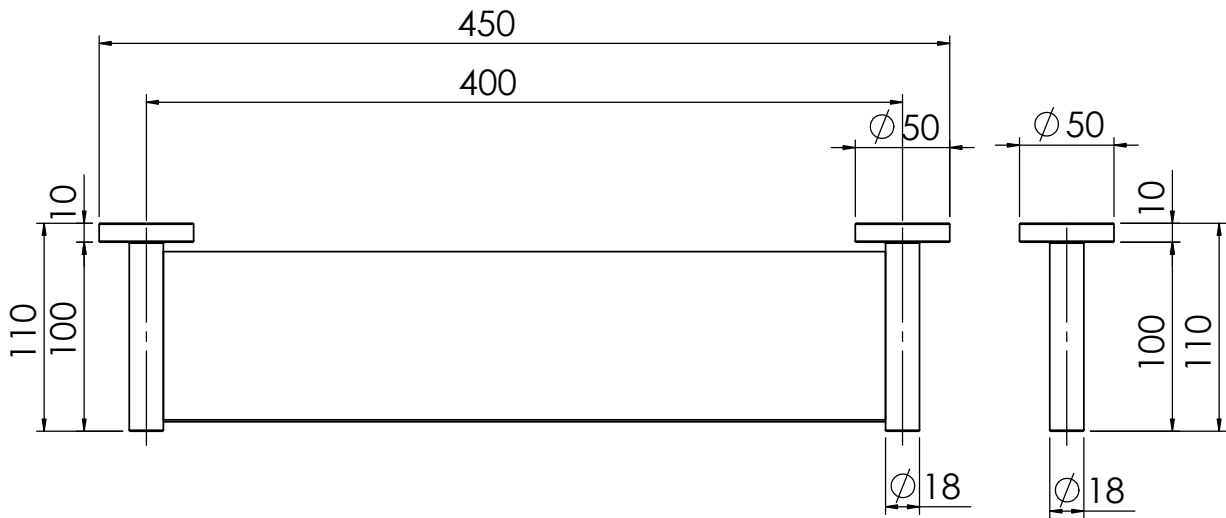
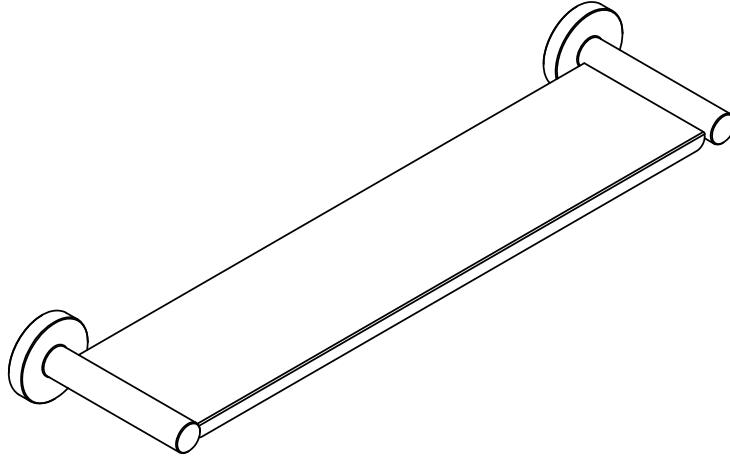

Bradley AUSTRALIA customised excellence	
DWG NO.	SR0941-16
APPROVED BY:	
Proudly customised design please approve	SCALE:1:3